

## i-BRUSH 2.0 SYSTEM

### THE OPTIMAL ONE-OF-A-KIND SYSTEM FOR REMOTE CARBON BRUSH MONITORING

#### i-BRUSH 2.0 plug-and-play system for generators & motors

Carbex i-BRUSH 2.0 system with integrated sensors in the carbon brush, with an external control unit, enables maintenance staff to check brush condition and performance characteristics at anytime from anywhere.

The tailor-made setup provides, you as a customer, a wide range of interfaces for your monitoring system.



#### SCHEMATIC OVERVIEW

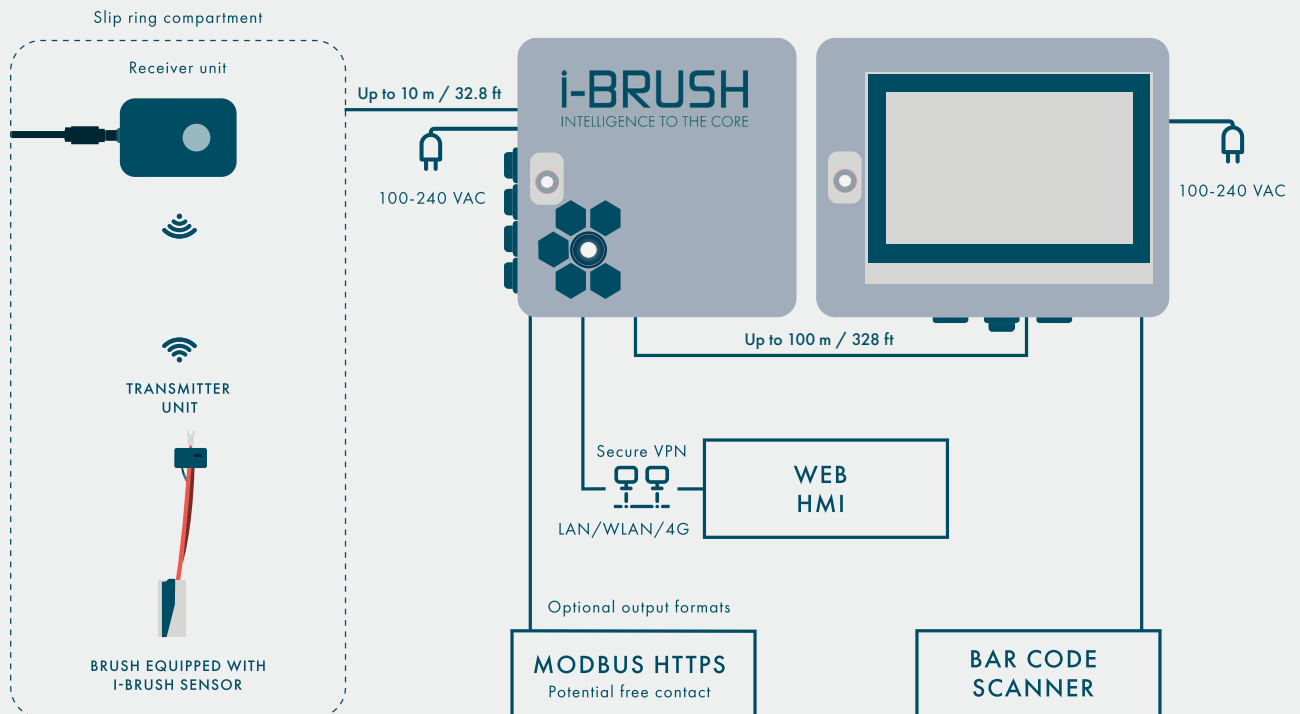

BEYOND THE BOUNDARIES OF BRUSH TECHNOLOGY

**CARBEX AB**  
BOX 115, SE-592 22  
VADSTENA, SWEDEN

+46 (0)143-294 40  
info@carbex.se  
carbonbrushsolution.com

USA Sales Contact

**OHIO CARBON INDUSTRIES, INC**  
1201 JACOBSON AVE ASHLAND  
OH 44805

888-248-5029  
sales@ohiocarbon.com  
ohiocarbon.com

## i-BRUSH 2.0 SYSTEM

Operating data can be displayed on any PC or HMI display. With knowledge of remaining brush life, the future maintenance can easily be planned to secure uptime.

### Carbex monitoring system

- Can be retrofitted to any existing installation.
- Fits most common brush holder/slip ring designs on the market.
- Regardless of brush grade, all types of brushes are available in i-BRUSH design.
- Designed to monitor up to 100+ brushes.
- Locally stored operating data.

### The key parameters monitored, logged and reported by i-BRUSH 2.0

- Brush wear.
- Temperature in the brush.
- Current in the brush.
- Current distribution between brushes.
- Brush vibrations (pk-pk).
- Temperature and humidity in slip ring compartment.

When one of the monitored values deviates from preset parameters an alarm is initiated.

### 24/7 BATTERY-FREE SOLUTION

|  |   |  |
|--|---|--|
|  <p><b>Reusable and battery free transmitters</b></p> <ul style="list-style-type: none"> <li>• The transmitter read and write the data from the carbon i-BRUSH sensor to the receiver.</li> </ul> |  <p><b>Receiver unit</b></p> <ul style="list-style-type: none"> <li>• The receiver has a built in temperature/humidity sensor and a wireless device.</li> </ul> |  <p><b>Carbon i-BRUSH</b></p> <ul style="list-style-type: none"> <li>• Measures wear, current vibration (as option) and temp per brush position.</li> </ul> |
|--|---|--|

### HMI DISPLAY (OPTION)

**A 12" touch screen can easily be added to the i-BRUSH system for quick and easy overview.**

HMI Display can be delivered with 3, 10, 30\*, 50 or 100m / 9.8, 32.8, 98.4\*, 164, 328 ft cable. Possibilities to connect external keyboard and mouse. A touch pen is included as standard.

\*Standard length

### Internet connection

Customer can choose between WLAN/LAN or 4G/WLAN/LAN  
Note: System can run without internet.

### External communication (optional)

Customer can choose between Modbus, Https or 4 potential free output relay.

BEYOND THE BOUNDARIES OF BRUSH TECHNOLOGY

## i-BRUSH 2.0 SYSTEM

### BENEFITS & FEATURES

#### Secure and safe operation

- Replacement of brushes is carried out easy and safely.
- Less interactions and inspections of complete slip ring unit.
- Less shutdowns due to maintenance work.

#### Reduces cost of maintenance

- Decreases need for repairs of potential slip ring damages which reduces downtime.
- Quick overview.
- The i-BRUSH system itself has minimal maintenance and low operating costs. Transmitters can be reused for several brush sets, and no battery replacement is required.

Maintenance is performed based on brush conditions rather than scheduled activities.

#### Increased workforce efficiency

- Enables maintenance staff to check brush condition at any time.
- Reduced site visits for inspection and maintenance.
- Time saving inspections, with longer intervals.

#### Better & safer maintenance

- Constant monitoring via HMI display alt. control rooms lead to more informed decisions.
- Constant data transfer 24/7.

#### Quick and easy installation

- Installation of the i-BRUSH system does not require any specialized expertise, and a minimum of electrical installation.
- Boxes attaches magnetically or by fasteners.

### CONFIGURATION

#### i-BRUSH box

- Control unit with integrated intelligence.
- Controlling up to 100+ brushes.
- Multicolor LED display for quick status overview.
- Pre-installed program with alarm settings etc.
- Internal data storage, with locally hosted software.
- Subscription of reports as an option.
- Standard power supply, AC 100-230VAC.
- Barcode scanner.

#### Transmitters

- Battery-free transmitters.
- Wireless brush communication up to 10 m / 32.8 ft between receiver and transmitter units.
- Reusable transmitters.

#### Receiver

- Built-in temperature/humidity sensor
- Wiring distance up to 10 m / 32.8 ft between receiver and i-BRUSH box

#### HMI Display (option)

- 12" Display.
- Display cable standard 30 m / 98.4 ft\*.
- Internet connection securely via VPN with internal firewall.
- Internet connection – WLAN/LAN or 4G/WLAN/LAN.
- Option to connect external DCS (Scada etc.).
- Access of installation manual via HMI display.

#### Dimension

- i-BRUSH Box: 300 x 300 x 155 mm / 11.8 x 11.8 x 6.1 in.
- HMI Box: 380 x 300 x 182 mm / 15 x 11.8 x 7.2 in.
- Receiver unit: 46 x 56 x 85 mm / 1.8 x 2.2 x 3.3 in.
- Transmitter unit: 29 x 45 x 28,4 mm / 1.4 x 1.8 x 1.12 in.

\*various lengths as option

BEYOND THE BOUNDARIES OF BRUSH TECHNOLOGY

## i-BRUSH 2.0 SYSTEM

### INTERFACE DESCRIPTION

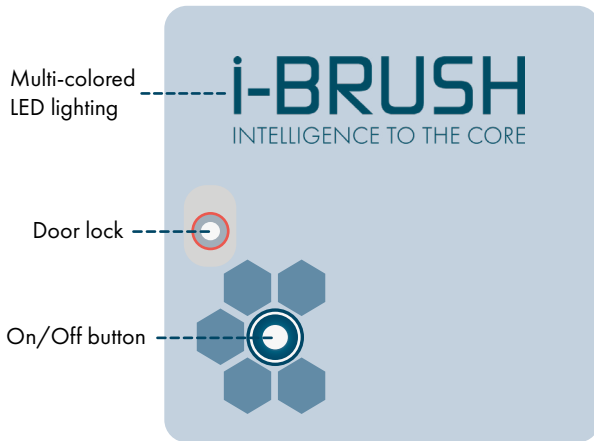

### SIDE PANEL

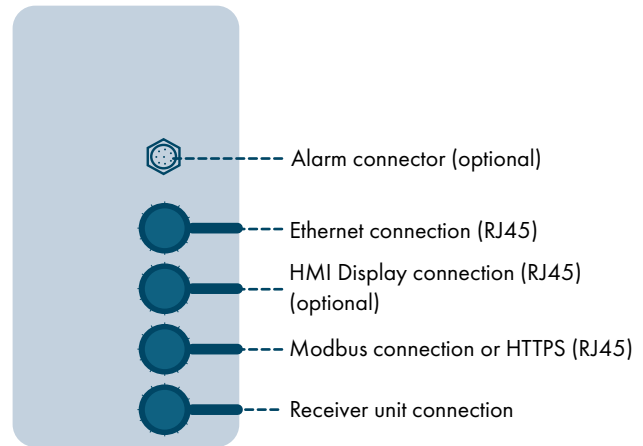

### BOTTOM PANEL

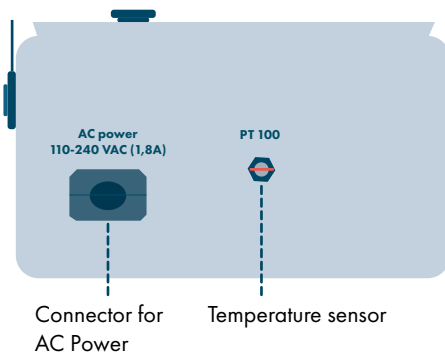

### ALARM OUTPUTS (OPTIONAL) I-2BR-SMS-2

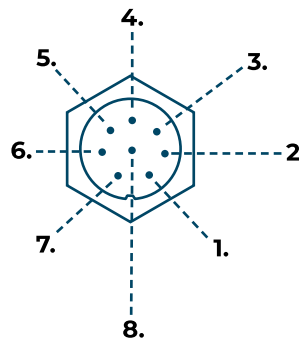

The four outputs are optoisolated, electronic relay outputs. They are rated 125 ACV 0,5A or 30 DCV 2 A

| PANEL CONTACT | RELAY CH            |
|---------------|---------------------|
| 1             | Relay 1, NO contact |
| 2             |                     |
| 3             | Relay 2, NO contact |
| 4             |                     |
| 5             | Relay 3, NO contact |
| 6             |                     |
| 7             | Relay 4, NO contact |
| 8             |                     |

### PRODUCT ID I-BRUSH BOX

|                                    |  |
|------------------------------------|--|
| Supply voltage                     | 100–240 VAC (1,8 A)                              |
| Alarm output (isolated) (optional) | 125 ACV 0,5A or 30 DCV 2 A (I-2BR.SMS-2)         |
| Internet connection                | VPN via internal firewall                        |
| IP Enclosure rating                | IP54   |
| Dimensions                         | 300 x 200 x 155 (175) mm<br>11.8 x 11.8 x 6.1 in |
| Weight                             | 10 kg  |
| Operating temperature              | -40–+60 °C                                       |
| Storage temperature                | -40–+85 °C                                       |
| Receiver unit cable                | Up to 10 m / 32.8 ft                             |
| HMI display cable                  | Up to 100 m / 328 ft                             |

### PRODUCT ID HMI DISPLAY BOX

|                         |  |
|-------------------------|--|
| Supply voltage          | 100–240 VAC (1,8 A)                      |
| IP Enclosure rating     | IP54                                     |
| Dimensions              | 380 x 300 x 182 mm<br>15 x 11.8 x 7.2 in |
| Weight                  | ≈ 10,2 kg                                |
| Operating temperature   | 0–+55 °C                                 |
| Storage temperature     | -20–+70 °C                               |
| HMI display cable       | Up to 100 m / 328 ft                     |
| Display size/resolution | 12.1 inch display 1280 x 800             |

BEYOND THE BOUNDARIES OF BRUSH TECHNOLOGY